



MARQUEST S C I E N T I F I C

Fluid Handling Products



TUFF GUARD[™] **GAUGE ISOLATORS**

FILLING REQUIRED

If unit has been purchased w/out a gauge

**Installation procedure
and parts list**

The Diaphragm

Your Marquest Gauge Isolator is supplied with a Teflon®, Viton®, or EPDM Diaphragm.

The diaphragm provides the isolation of the process media from the pressure sensing instruments. Should it become necessary to replace the diaphragm, the following procedure should be used as depicted by the diaphragm material. When using Viton® or EPDM diaphragms, simply unscrew the chambers from each other. The diaphragm may then be removed and its replacement set into position. Screw the two chambers together so that the diaphragm seals in the sealing grooves provided by the two chambers. It may be necessary to wrench tighten a quarter turn after firmly tightening by hand. When replacing a Teflon® diaphragm, wrenches are required as additional torque is necessary to unseal and reseal the diaphragm.

Chemical Resistance Data

Chemical resistance data is not provided by Marquest Scientific due to the complex potential of combinations, concentrations, temperature and degree of safety factors required.

A specific inquiry to Marquest providing complete service data and service requirements will provide you with an opinion as to suitability.

Marquest cannot guarantee suitability for any service.

Teflon® and Viton® are Registered Trademarks of E.I. DuPont.

Please... read these instructions...

The Marquest Gauge Isolator is designed to isolate and protect pressure sensing instruments from process media. This is accomplished by the impermeable diaphragm. The instrument side of the gauge isolator is filled with a compatible liquid that will transmit the pressure of the processing system to the instrument. The inherent volumetric and sensing area design features allow an accurate transmittal of pressure.

INSTALLATION

Installation of the Marquest Gauge Isolator, when purchased with a gauge, is performed by simply connecting it to the processing system with a 1/4" or 1/2" NPT plastic nipple. Teflon® tape is recommended as a thread sealant. Pipe dope, not specifically recommended for plastic pipe by the manufacturer, should not be used. A firm hand tight torque is normally sufficient for small plastic pipe threads; over-tightening may deform threads and could cause leaking.

Installation of the Marquest Gauge Isolator, when purchased without a gauge is accomplished in the following manner:

1. Fill the upper chamber of the Gauge Isolator with a compatible liquid by pouring the fill liquid through the instrument outlet orifice. The spherical design of the chamber will allow the air to evacuate the chamber, providing the orifice is not bridged by the fill liquid.

The chamber shall be considered full when the liquid level reaches the mid-point of the thread.

2. The gauge or instrument may be filled in the same manner, although a small probing device may be necessary to evacuate the trapped air. For certain applications where a high degree of accuracy is imperative, the instrument should be filled on a vacuum manifold device.

3. The standard orifices on most gauge are such that the fill liquid will be retained when the orifice is faced down and in position to thread into the Gauge Isolator. Teflon® tape is recommended as the thread sealant. Hand tighten instrument to Gauge Isolator.

NOTE: Air left in the chamber or instrument may cause some loss in accuracy of the instrument reading. However, the internal design features of the Gauge Isolator will tolerate some void of fill liquid.

4. Connect to the processing system using a 1/4" or 1/2" NPT plastic nipple using Teflon® tape as the recommended thread sealant.

The standard gauge furnished with the Gauge Isolator, when ordered as such, is 2" diameter, lower mount. The case and ring are drawn steel, black corrosion resistant painted. Windows are flat glass. Dial is steel; white background with black markings. Movement is brass. Bourdon tube is phosphor bronze except in vacuum and 15 psi type where beryllium copper is used as the tube material.

Dimensions

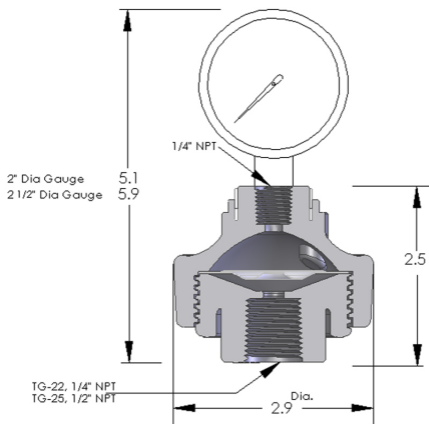

How To Order

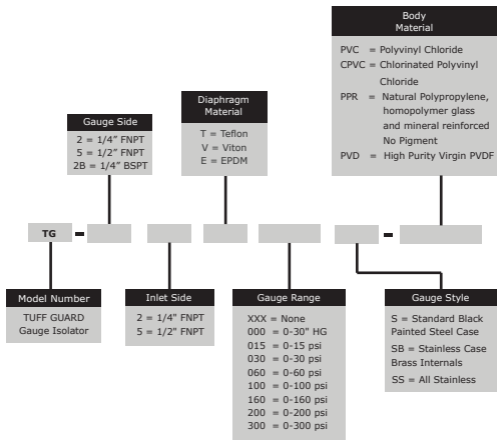

Example Part Number: TG-25T060S-PVC

Tuff Guard Gauge Isolator with 1/4" Female NPT Outlet, 1/2" Female NPT Inlet, Convoluted Teflon Diaphragm, w/ 0-60 PSI Standard Black Painted Steel Case Gauge with Brass Internals, Polyvinyl Chloride Body

Notes:

- Dual Scale Dials Available
- Max Pressure Rating is 250 psi

Pressure/Temperature Range

WORKING PRESSURES PSI

WEIGHTS

| Material | 10°C 50°F | 20°C 68°F | 30°C 86°F | 40°C 104°F | 50°C 122°F | 60°C 140°F | 70°C 158°F | 80°C 176°F | 90°C 194°F | 100°C 212°F | 120°C 248°F | Net Weights Pounds* |
|----------|--------------|--------------|--------------|---------------|---------------|---------------|---------------|---------------|---------------|----------------|----------------|------------------------|
| PVC | 200 | 250 | 250 | 220 | 140 | 135 | — | — | — | — | — | 0.33 |
| CPVC | 230 | 250 | 250 | 230 | 200 | 200 | 150 | 120 | 60 | — | — | 0.36 |
| PP | 200 | 240 | 240 | 210 | 145 | 125 | 75 | 60 | — | — | — | 0.31 |
| PVDF | 240 | 250 | 250 | 250 | 250 | 230 | 220 | 200 | 160 | 140 | 80 | 0.39 |

Temperature Ranges: PVC: 14 to 140°F (10 to 60°C), CPVC: 50 to 194 F (10 to 90°C), PP: 46 to 176°F (8 to 80°C), PVDF: -22 to 248°F (-30 to 120°C). * Weights are for unfilled 1/4" x 1/2" without gauges.

Quality, Availability, Service, Value

MADE IN USA



MARQUEST S C I E N T I F I C

F L U I D H A N D L I N G P R O D U C T S

2950 Airway Avenue Bldg C-5 Costa Mesa, CA 92626

714.491.9191 Fax: 714.491.9199

www.marquestscientific.com

sales@marquestscientific.com